

SECTION 1
NTS

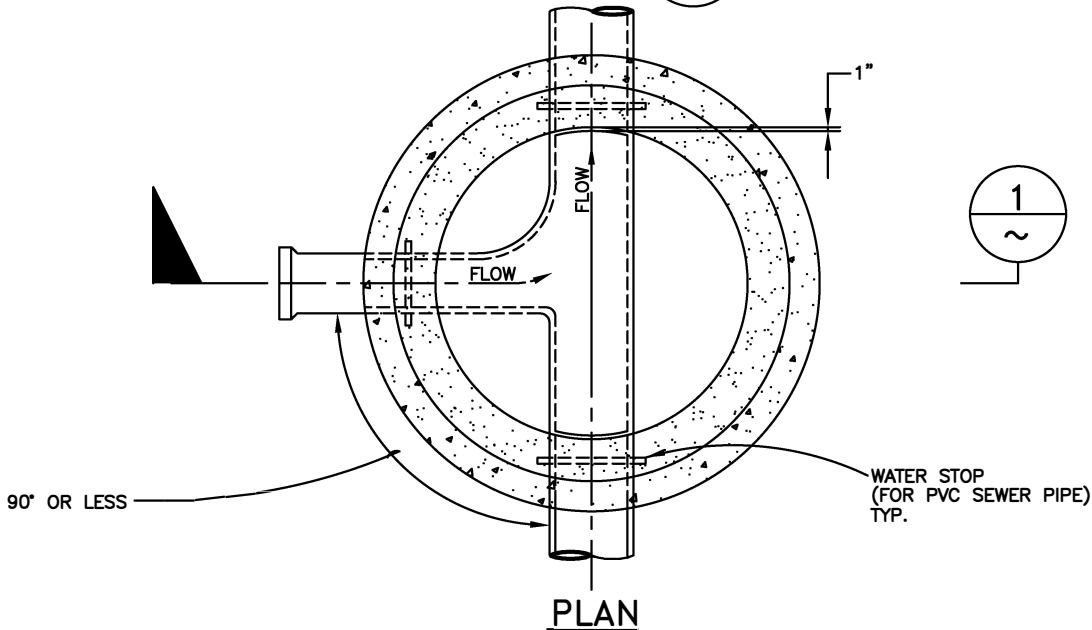

NOTES:

1. SEE SPEC. SEC. III-A5-7 FOR CRITERIA ON MANHOLE SIZING. NTS
2. MANHOLE SHALL HAVE NO STEPS.
3. USE JOINT SEALANT FROM APPROVED MATERIALS LIST BETWEEN JOINTS. TRIM ALL JOINTS AFTER COMPLETION.
4. JOINTS SHALL BE WRAPPED WITH 9-INCH EXTERNAL CONCRETE JOINT WRAP FROM APPROVED MATERIALS LIST.
5. 5" WALL THICKNESS FOR MANHOLES UP TO 4-FT DIAMETER AND 6" WALL THICKNESS FOR 5-FT DIAMETER MANHOLES.

Dublin San Ramon Services District

DATE
DEC 2020

STANDARD MANHOLE

REVISED BY
RM

SIGNED COPY ON FILE AT DISTRICT OFFICE

DRAWING
S-2