

ADJUSTMENT TO FINISH GRADE DETAIL

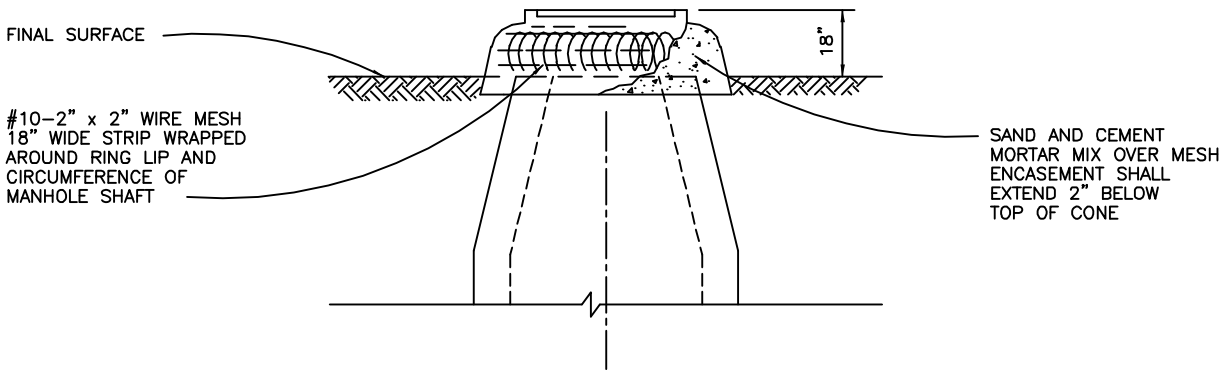

MANHOLE SECURING DETAIL FOR UNDEVELOPED AREA

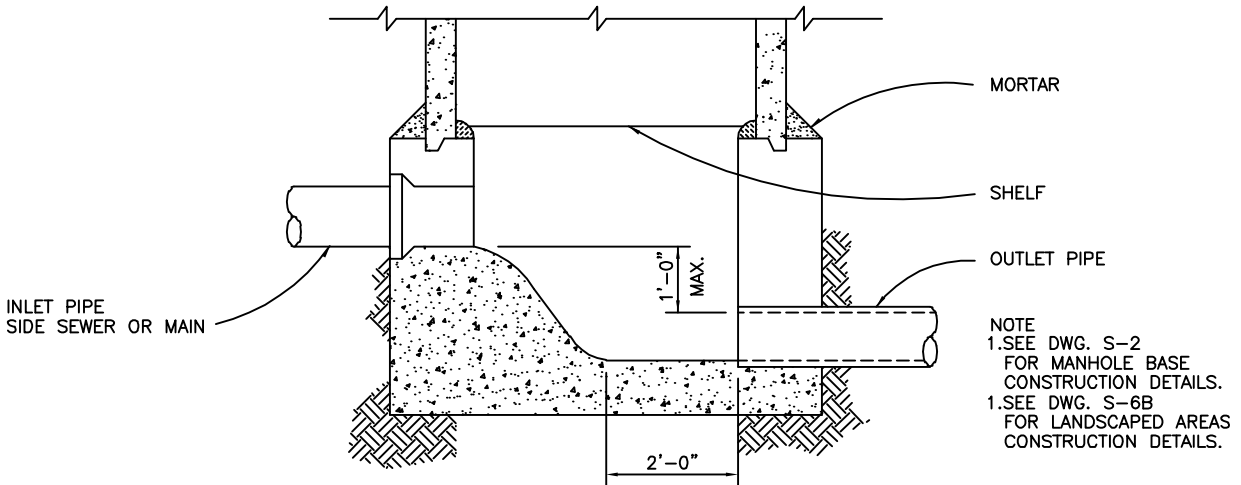

ALLOWABLE DROP IN MANHOLES

REV. 05-14-2018

Dublin San Ramon Services District	DATE DEC 2019
MISCELLANEOUS MANHOLE DETAILS	DESIGNED KP
SIGNED COPY ON FILE AT DISTRICT OFFICE	DRAWING S-6