

CONCRETE CRADLE DIMENSIONS			
VALVE SIZE	A	B	C
6"	9"	4"	6"
8"	12"	6"	8"
10"	16"	8"	10"
12"	20"	10"	12"

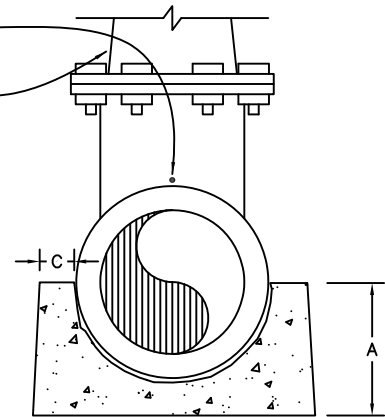

NOTES:

1. COAT ALL BONNET BOLTS, GLAND, GLAND BOLTS AND STEM WITH BITUMINOUS PAINT, SEE SPECS.
2. ON MAINS WHERE VALVES ARE TO BE INSTALLED ADJACENT TO TEES OR CROSSES, THE VALVES SHALL BE FLG x MJ WITH FLANGED END BOLTED DIRECTLY TO THE TEE OR CROSS.
3. IN-LINE VALVES SHALL HAVE RESTRAINED MJ ENDS, WHERE NOT CONNECTING TO A FLANGED FITTING.
4. CENTERING RING PER SECTION II-B1-2.06 OF THESE STANDARDS.
5. ALL BOLTS SHALL BE STAINLESS STEEL TYPE 316, OR APPROVED EQUAL. ANTI-SEIZE LUBRICANT SHALL BE APPLIED TO BOLT THREADS. POLYWRAP ALL FERROUS PIPE AND FITTINGS.
6. CONCRETE CRADLE FOR VALVE SHALL BE FORMED AND NOT ENCASE FITTINGS.
7. CATHODIC PROTECTION IS REQUIRED.

Dublin San Ramon Services District

GATE VALVE INSTALLATION
12" GATE VALVE AND SMALLER

SIGNED COPY ON FILE AT DISTRICT OFFICE

REVISION DATE
DEC 2019

REVISED BY
KP/BD

DRAWING
W-13