

PLAN

NTS

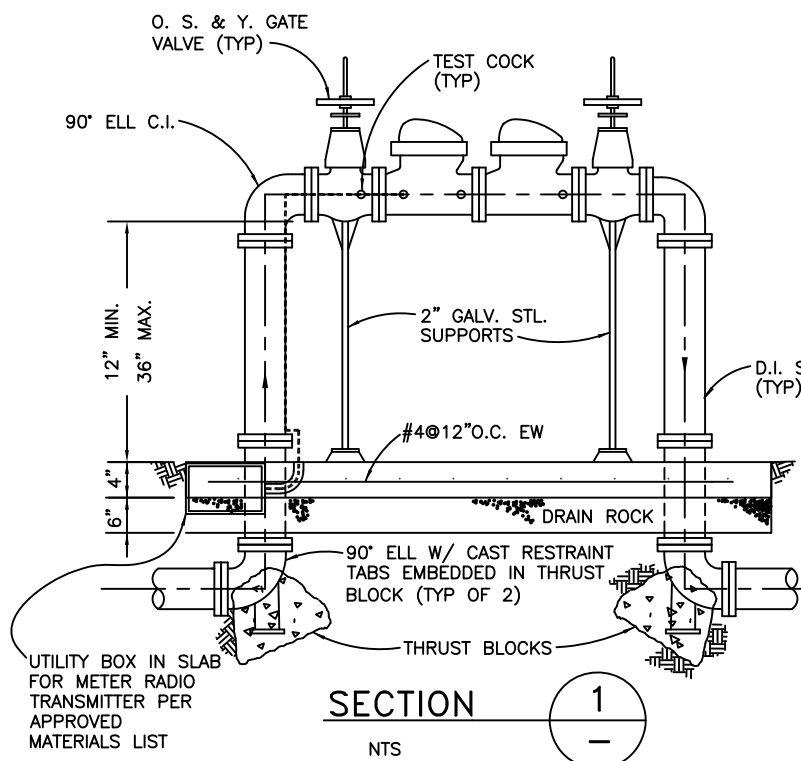

SECTION 1

NTS

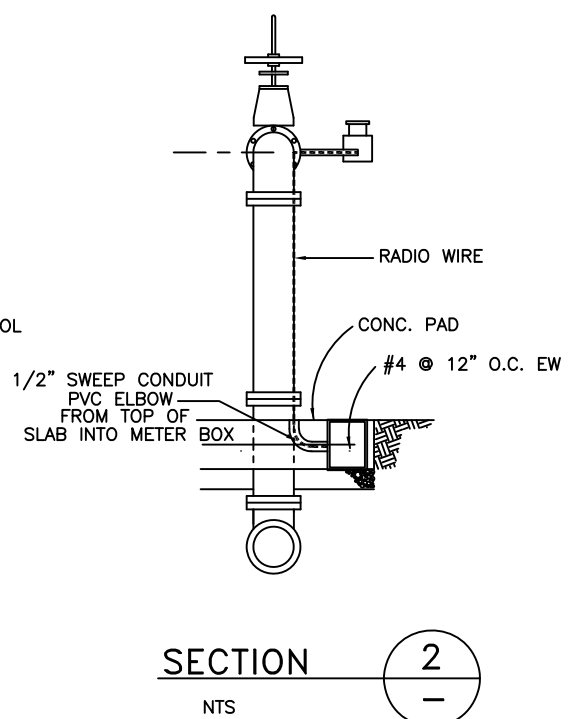

SECTION 2

NTS

NOTES:

1. DOUBLE DETECTOR CHECK ASSEMBLY SHALL BE FACTORY ASSEMBLED COMPLETE, WITH METER AND DETECTOR CHECKS AND SHALL BE ON DISTRICT APPROVED LIST. THE DETECTOR METER SHALL BE SUPPLIED WITH A RADIO-READ NEPTUNE OR SENSUS METER. THE METER INTERFACE UNITS SHALL BE DATAMATIC FIREFLY METER INTERFACE UNITS FOR AMR SYSTEMS USING ENCODED REGISTERS WITH PROFILE PLUS LOAD PROFILING CAPABILITY.
2. INSTALL AS REQUIRED.
3. RADIO WIRE TO BE FIRMLY AFFIXED TO PIPING WITH WIRE TIES.
4. TRANSMITTER TO BE SPLICED TO INCOMING WIRES WITH WATER PROOF CONNECTORS.
5. METER SHALL BE SET TO READ IN CUBIC FEET.
6. DEVICE SHALL BE TESTED BY CERTIFIED TESTER. TEST REPORT SHALL BE SUBMITTED TO DSRSD.
7. PROTECTIVE ENCLOSURE NOT SHOWN. REFER TO SECTION II-B2-7 AND DRAWING W-25 FOR ENCLOSURE REQS.
8. ALL BOLTS SHALL BE STAINLESS STEEL TYPE 316, ANTI-SEIZE LUBRICANT SHALL BE APPLIED TO BOLT THREADS. POLYWRAP ALL FERROUS PIPE AND FITTINGS.

Dublin San Ramon Services District	REVISION DATE DEC 2020
DOUBLE DETECTOR CHECK FOR 2" - 10" FIRE LINES ABOVE GROUND INSTALLATION	REVISED BY RM
SIGNED COPY ON FILE AT DISTRICT OFFICE	DRAWING W-23