

(BOTTOM SIDE OF PLATE)

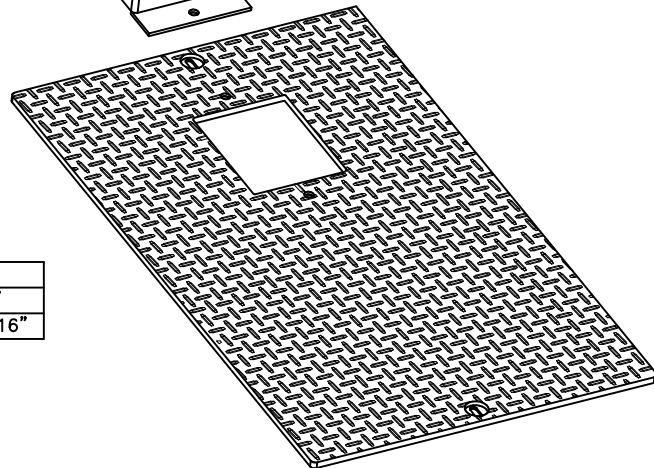
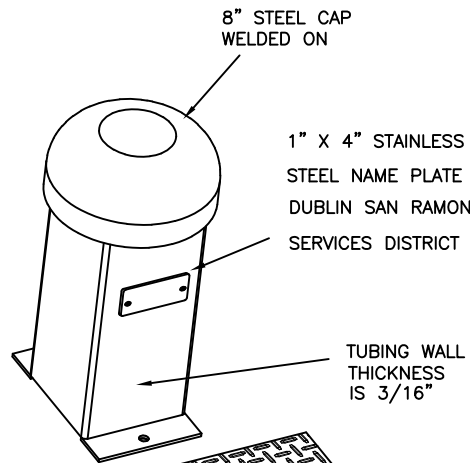
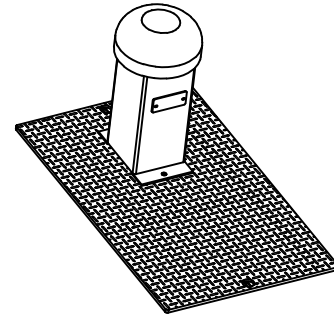

	LID / PLATE SIZE
FOR 1" CAV	16-1/4" X 27" X 3/16"
FOR 2" CAV	20-1/4" X 33-1/4" X 3/16"

NOTES:

1. VALVE COVER TO BE ON APPROVED MATERIALS LIST, OR APPROVED EQUAL.
2. CLEAN INTERIOR AND EXTERIOR OF STEEL WITH A WATER-BASED CLEANER.
3. APPLY PRIMER 2-3 MILLS THICK WITH TWO PART CATALYZED POLYAMID EPOXY PRIMER (HUNTER GREEN FOR POTABLE WATER OR PURPLE FOR RECYCLED WATER), OR APPROVED EQUAL PRIMER.
4. APPLY ALIPHATIC URETHANE FINISH TOP COAT.
5. VALVE VENT COVER AND LID TO BE PAINTED HUNTER GREEN FOR POTABLE WATER OR PURPLE FOR RECYCLED WATER.

Dublin San Ramon Services District

REVISION DATE
JUN 2020

AIR RELEASE & VACUUM RELIEF
VALVE VENT COVER

REVISED BY
RM/BD

SIGNED COPY ON FILE AT DISTRICT OFFICE

DRAWING
W-27